

PTR-200

Fiber Recoating and Proof Testing



**A Complete Series of Products for
Coating Restoration and Reliability Testing**



The PTR-200 Series

Vytran Corporation is the world's leading provider of optical fiber recoaters and proof testers. With the introduction of our PTR-200 Series of products, Vytran continues this leadership position with the automation of recoating and proof testing for high volume optical fiber processing. Various module configurations allow the customer to select among three types of recoat stations - manual, extended length manual, or automatic - and two types of proof test stations - rotary or linear. These stations can be ordered individually or in selected recoat/proof test combinations as listed in the Module Configuration table below.

Module Configurations

- **MRC** - Manual Fiber Recoater with Auto Injection
- **XLR** - Extended Length Recoater with Auto Injection
- **ARC** - Fully Automated Fiber Recoater
- **RPT** - Rotary Proof Tester / Tension Tester
- **LPT** - Linear Proof Tester
- **MRL** - Combination Manual Recoater & Linear Proof Tester
- **MRR** - Combination Manual Recoater & Rotary Proof Tester
- **ARL** - Combination Automatic Recoater & Linear Proof Tester

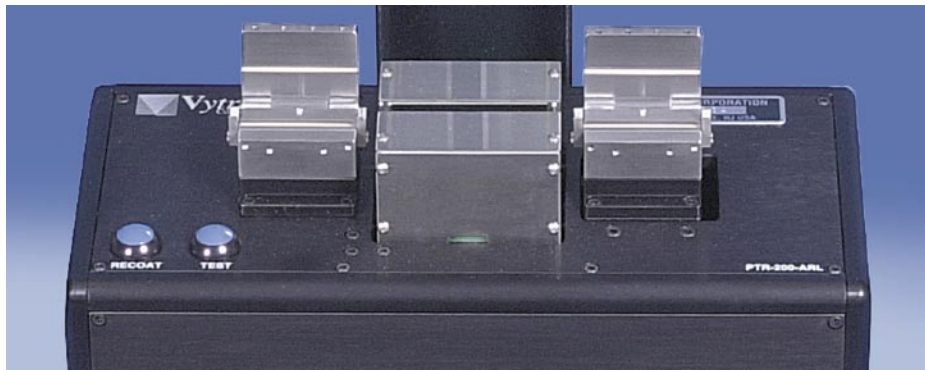

PTR-200-ARL

Advantages

- Flexible Splice Protection
- High Density Splice Packaging
- Long Term Reliability
- High Volume Production Processing

High Reliability Coating Restoration

Vytran optical fiber recoaters restore the protective UV acrylate buffer coating to a stripped or fusion spliced section of optical fiber. Because the recoat diameter and recoat material can be closely matched to the original fiber, the recoated section of fiber is smooth and flexible, and can be handled or coiled just like the original fiber. When used in conjunction with a proof test qualification, recoating offers significant packaging and reliability advantages over standard heat shrink protection sleeves.

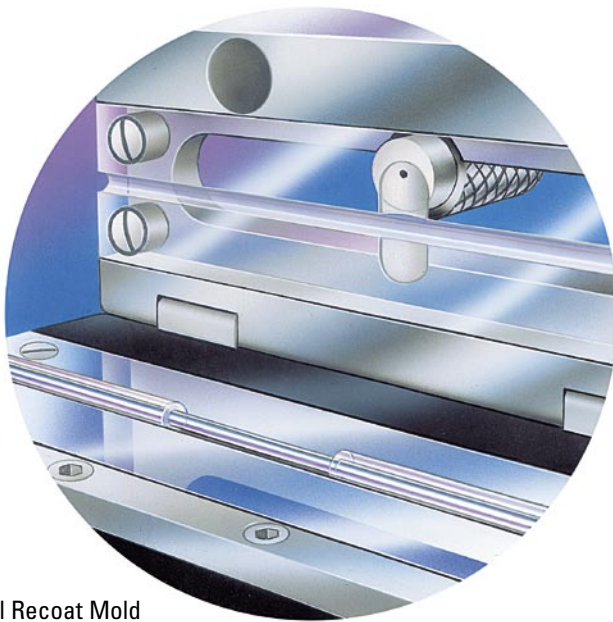

Manual Recoat Mold

All Vytran recoaters use split quartz mold plates, which, when closed together, form a circular mold cavity around the exposed section of fiber. A volumetric dispensing pump automatically injects a pre-programmed amount of recoat material into the mold cavity, which is then cured by exposure to ultraviolet (UV) light. Special optical coatings on the surfaces of the mold plates prevent any recoat material that migrates between the plates from curing and forming a "flash" on the finished recoat.

The manual recoat mold has a hinged top that is opened and closed "manually". Recoat material is injected into the mold cavity via a cross channel in the mold top plate. The manual mold is well suited for R&D applications, low-volume requirements, or if the mold size or process must be changed frequently. An extended length version of the manual recoat mold is available for Fiber Bragg Gratings and similar applications where stripped sections of fiber longer than 50 mm need to be recoated.

The automatic recoat mold uses a pneumatic gripper assembly to "automatically" open and close the mold plates in a front-to-back direction. The recoat mold plates are very thick in order to hold true optically flat mating surfaces. This allows direct injection of the recoat material into the mold cavity without any excess material to clean after every recoat. Once the fiber is positioned in the fiber holding blocks, the entire recoat process is performed automatically. Continuous, fully automatic operation makes this an ideal system for high-volume fiber processing.

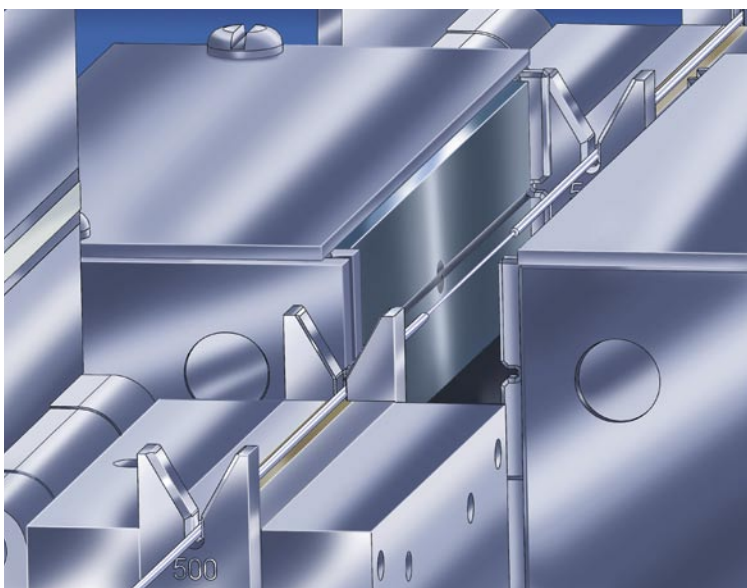

Automatic Recoat Mold

Proof Testing / Tension Testing

Vytran optical fiber proof testers apply a set load at a controlled rate to an optical fiber or fusion splice. The load can be taken up to a pre-determined level and released - proof test mode - or it can be taken up to the breaking strength of the fiber - tension test mode. The peak tension is recorded and can be displayed in units of tension (pounds, kilograms or Newtons) or stress (kpsi or GPa). By selecting a proof test level approximately three times higher than the applied service load on the fiber or fusion splice, the long-term reliability of the fiber can be assured.



PTR-200-MRL

The linear optical fiber proof tester is intended for production proof testing of up to 20 Newtons (235 kpsi for a 125 micron fiber). The section of fiber to be proof tested is located between left and right-hand fiber holding blocks that move linearly to apply the load. Rubber inserts within the fiber holding blocks tightly grip the fiber without damaging the coating. The linear proof tester can be combined with either the manual or automatic recoater, providing the advantage that only one loading step is required for both processes. This makes the linear proof tester well suited for high volume production processing.

The rotary optical fiber proof tester / tension tester features Vytran's rotating mandrel design. To proof or tension test a fiber, the section of fiber to be tested is located between two mandrels. The ends of the fibers are wrapped once around each mandrel and held in place by an integral clamping mechanism. A load is automatically applied to the fiber by the rotation of the right-side mandrel. The rotary proof tester is ideal for process qualification where high proof test / tension test levels are required.



PTR-200-RPT

Module Configuration

Module Configurations	Manual Fiber Recoating	Automatic Fiber Recoating	Automatic Recoat Injection	Rotary Proof Testing	Linear Proof Testing
MRC Module*	●		●		
XLR Module**	●		●		
RPT Module				●	
ARC Module*		●	●		
LPT Module					●
ARL Module*		●	●		●
MRL Module*	●		●		●
MRR Module*	●		●	●	

*Maximum recoat length is two inches (50mm).

**Maximum recoat length is four inches (100mm).

All Modules offer a choice of control/display interface. The standard interface is a touch screen panel display that provides system status and programming capabilities. Vytran also offers a mini-controller display, which provides system status only. The mini-display is a common option for repetitive production applications where the operator does not need to change process parameters. If process parameters do need to be changed on a system equipped with a mini-controller, Vytran offers a hand-set controller that can be temporarily connected to the machine for re-programming. All modules can also be controlled directly over their RS-232 interface, providing easy integration into existing manufacturing control software.



www.vytran.com

PTR-200 Specification

General Dimensions

Base Module (except MRR):	H: 5.0" (127 mm), W: 10.25" (260 mm), D: 5.0" (127 mm).
Base Module (MRR):	H: 5.0" (127 mm), W: 10.25" (260 mm), D: 7.0" (178 mm).
Control Panel:	H: 5.0" (127 mm), W: 8.0" (203 mm), D: 1.0" (25 mm).
External Power Supply:	H: 2.4" (60 mm), W: 4.1" (105 mm), D: 12.5" (320 mm).

Electrical Requirements

Base Module:	12.5 VDC, 13 A. (Provided by external powers supply)
Control Panel:	12.5 VDC, 500 mA. (Provided from base module)
External Power Supply:	Voltage: 100-120 / 200-240 VAC. Current: 4.5 / 2.2 A. Frequency: 47-63 Hz.

Supply Requirements

ARC Module:	Vacuum for fiber holding blocks (external vacuum pump provided)
ARC, ARL Modules:	80-120 psi dry compressed air or gas for pneumatic gripper.

Interface

Base Module:	RS-232 Serial Communication.
--------------	------------------------------

Recoating

Recoating	Manual	Automatic
Modules:	MRC, XLR, MRR	ARC, ARL
Recoat Mold:	Quartz.	Quartz.
Recoat Diameter:	260µm std. for nominal 250µm fiber Custom sizes from 200µm and up.	280µm std. for nominal 250 µm fiber. Custom sizes are available.
Maximum Recoat Length:	2" (50 mm) for MRC, MRR Modules. 4" (100 mm) for XLR Module.	2" (50 mm) for ARC, ARL Modules.
Recoat Material:	UV Curable Acrylate. DSM 950-200 recommended.	UV Curable Acrylate. DSM 950-200 recommended.
UV Source:	Four 10 W halogen lamps, for MRC. Eight 10 W halogen lamps, for XLR.	32 UV LEDs
Recoat Injection:	Automatic, direct from 1 oz. bottle.	Automatic, direct from 1 oz. bottle.
Recoat Volume:	Programmable in microliters, 5µl typical.	Programmable in microliters, 1.5µl typical.
Recoat Inject Rate:	Programmable, up to 1.8µl/s.	Programmable, up to 1.8µl/s.
Inject/Lamp-on Delay Time:	Programmable, 5s typical.	Programmable, 5s typical.
Cure Time:	Programmable, 17s typical.	Programmable, 17s typical.
Mold Cleaning Requirement:	After every recoat.	Start-up and shut-down only.
Mold Open/Close Method:	Manual.	Automatic (pneumatic gripper).
Total Cycle Time:	60s typical.	45s typical

Proof Testing

Proof Testing	Rotary	Linear
Modules:	RPT, MRR	LPT, MRL, ARL
Load Application:	Rotating Mandrel.	Linear Fiber Clamp.
Mandrel Diameter:	2" (51 mm).	N/A
Fiber Clamp Length:	N/A.	1.5" (38 mm).
Fiber Spacing:	5" (127 mm).	2.9" (74 mm).
Min. Fiber Length Req.:	17" (432 mm).	6" (150 mm).
Maximum Load:	20 lbs., 9.1 kg. >800 kpsi (5.5 Gpa) for 125µm fiber.	4.5 lbs., 2.1 kg. 235 kpsi (1.6 Gpa) for 125 µm fiber.
Accuracy:	+/- 2%	+/- 2%.
Ramp Rate:	Manual adjust up to 5 lbs/s (2.3 kg/s).	Programmable, up to 5 lbs/s (2.3 kg/s).
Hold Time:	N/A.	Programmable.
Display Units:	lbs, kg, N, kpsi, GPa.	lbs, kg, N, kpsi, GPa.

